



# Low-Voltage, High-Accuracy, Quad Window Voltage Detectors in Thin QFN

## General Description

The MAX16008/MAX16009 are adjustable quad window voltage detectors in a small thin QFN package. These devices are designed to provide a higher level of system reliability by monitoring multiple supply voltages and providing a fault signal when any of the voltages exceed their overvoltage thresholds or fall below their undervoltage thresholds.

These devices offer user-adjustable thresholds that allow voltages to be monitored down to 0.4V. These devices allow the upper and lower trip thresholds of each window detector to be set externally with the use of three external resistors.

Each monitored threshold has an independent open-drain output for signaling a fault condition. The outputs can be wire OR'ed together to provide a single fault output. The open-drain outputs are internally pulled up with a 30 $\mu$ A current, but can be externally driven to other voltage levels for interfacing to other logic levels.

Both devices feature a margin input to disable the outputs during margin testing or any other time after power-up operations. The MAX16009 offers a reset output that deasserts after a reset timeout period after all voltages are within their threshold specifications. The reset timeout is internally set to 140ms (min), but can be externally adjusted to other reset timeouts using an external capacitor. In addition, the MAX16009 offers a manual reset input.

All devices are offered in a 4mm x 4mm thin QFN package and are fully specified from -40°C to +125°C.

## Applications

Storage Equipment  
Networking/Telecommunications Equipment  
Multivoltage ASICs  
Servers

Pin Configurations and Selector Guide appear at end of data sheet.



## Features

- ◆ Monitor Four Undervoltage/Overvoltage Conditions
- ◆ 1.5% Accuracy Over Temperature
- ◆ User-Adjustable Thresholds (Down to 0.4V)
- ◆ Open-Drain Outputs with Internal Pullups Reduce the Number of External Components
- ◆ Manual Reset Input (MAX16009)
- ◆ Margin Enable Input
- ◆ Fixed or Adjustable RESET Timeout (MAX16009)
- ◆ Guaranteed Correct Output Logic State Down to VCC = 1V
- ◆ Fully Specified from -40°C to +125°C
- ◆ Small, 4mm x 4mm Thin QFN Package

## Ordering Information

PART	TEMP RANGE	PIN-PACKAGE	PKG CODE
MAX16008TP+	-40°C to +125°C	20 Thin QFN	T2044-3
MAX16009TG+	-40°C to +125°C	24 Thin QFN	T2444-4

+ Denotes lead-free package.

For tape-and-reel, add a "T" after the "+." Tape-and-reel are offered in 2.5k increments.

## Typical Operating Circuit

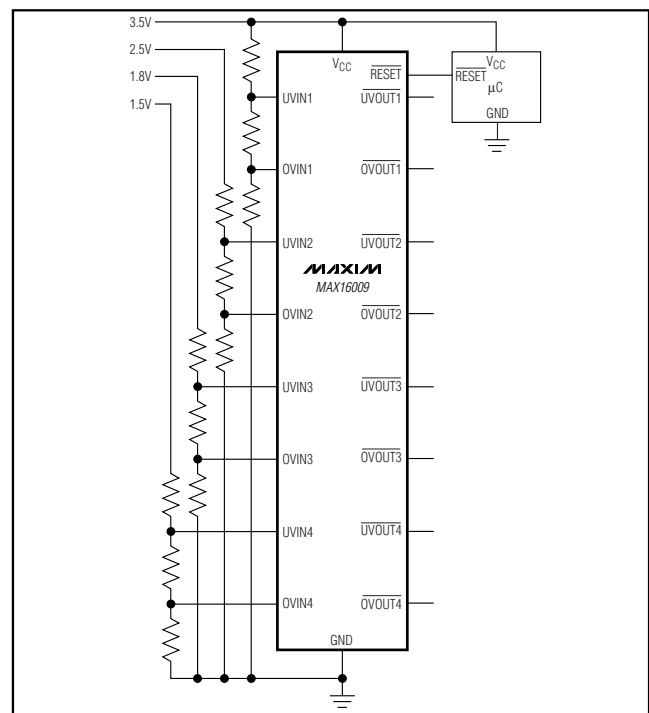

MAX16008/MAX16009

# Low-Voltage, High-Accuracy, Quad Window Voltage Detectors in Thin QFN

## ABSOLUTE MAXIMUM RATINGS

$V_{CC}$ ,  $\overline{OVOUT}_-$ ,  $\overline{UVOUT}_-$ ,  $\overline{RESET}_-$ ,  
 $\overline{UVIN}_-$ ,  $\overline{OVIN}_-$  to GND ..... -0.3V to +6V  
 $\overline{MARGIN}_-$ ,  $\overline{MR}_-$ ,  $\overline{TOL}_-$ ,  $\overline{SRT}$  to GND ..... -0.3V to ( $V_{CC} + 0.3V$ )  
 Input/Output Current  
 ( $\overline{RESET}_-$ ,  $\overline{MARGIN}_-$ ,  $\overline{SRT}_-$ ,  $\overline{MR}_-$ ,  $\overline{UVOUT}_-$ ,  $\overline{OVOUT}_-$ ) .....  $\pm 20mA$   
 Continuous Power Dissipation ( $T_A = +70^\circ C$ )  
 20-Pin Thin QFN (derate 16.9mW/ $^\circ C$  above  $+70^\circ C$ ) ..... 1355mW  
 24-Pin Thin QFN (derate 16.9mW/ $^\circ C$  above  $+70^\circ C$ ) ..... 1666mW

Operating Temperature Range .....  $-40^\circ C$  to  $+125^\circ C$   
 Junction Temperature .....  $+150^\circ C$   
 Storage Temperature Range .....  $-65^\circ C$  to  $+150^\circ C$   
 Lead Temperature (soldering, 10s) .....  $+300^\circ C$

Stresses beyond those listed under "Absolute Maximum Ratings" may cause permanent damage to the device. These are stress ratings only, and functional operation of the device at these or any other conditions beyond those indicated in the operational sections of the specifications is not implied. Exposure to absolute maximum rating conditions for extended periods may affect device reliability.

## ELECTRICAL CHARACTERISTICS

( $V_{CC} = 2.0V$  to  $5.5V$ ,  $TOL = GND$ ,  $T_A = -40^\circ C$  to  $+125^\circ C$ , unless otherwise specified. Typical values are at  $V_{CC} = 3.3V$ ,  $T_A = +25^\circ C$ .)  
 (Note 1)

PARAMETER	SYMBOL	CONDITIONS	MIN	TYP	MAX	UNITS
Operating Voltage Range	$V_{CC}$	(Note 2)	1.0		5.5	V
Supply Current (Note 3)	$I_{CC}$	$V_{CC} = 3.3V$ , outputs deasserted		45	65	$\mu A$
		$V_{CC} = 5V$ , outputs deasserted		45	70	
UVLO (Undervoltage Lockout)	$V_{UVLO}$	$V_{CC}$ rising	1.62	1.8	1.98	V
<b><math>\overline{UVIN}_-</math>/<math>\overline{OVIN}_-</math></b>						
Adjustable Threshold ( $\overline{UVIN}_-$ Falling/ $\overline{OVIN}_-$ Rising)	$V_{TH}$		0.388	0.394	0.400	V
$\overline{UVIN}_-$ / $\overline{OVIN}_-$ Hysteresis	$V_{TH\_HYS}$	$\overline{UVIN}_-$ falling/ $\overline{OVIN}_-$ rising (percentage of the threshold)		0.5		% $V_{TH}$
$\overline{UVIN}_-$ / $\overline{OVIN}_-$ Input Current	$I_{IB}$		-100		+100	nA
<b><math>\overline{RESET}_-</math></b>						
Reset Timeout	$t_{RP}$	$SRT = V_{CC}$	140	200	280	ms
		$C_{SRT} = 1500pF$ (Note 4)	2.43	3.09	3.92	
		$C_{SRT} = 100pF$		0.206		
		$C_{SRT} = open$		0.05		
SRT Ramp Current	$I_{SRT}$	$V_{SRT} = 0$	460	600	740	nA
SRT Threshold			1.173	1.235	1.293	V
SRT Hysteresis				100		mV
$\overline{UVIN}_-$ / $\overline{OVIN}_-$ to Reset Delay	$t_{RD}$	$\overline{UVIN}_-$ falling/ $\overline{OVIN}_-$ rising		20		$\mu s$

# Low-Voltage, High-Accuracy, Quad Window Voltage Detectors in Thin QFN

MAX16008/MAX16009

## ELECTRICAL CHARACTERISTICS (continued)

( $V_{CC} = 2.0V$  to  $5.5V$ ,  $TOL = GND$ ,  $T_A = -40^{\circ}C$  to  $+125^{\circ}C$ , unless otherwise specified. Typical values are at  $V_{CC} = 3.3V$ ,  $T_A = +25^{\circ}C$ .) (Note 1)

PARAMETER	SYMBOL	CONDITIONS	MIN	TYP	MAX	UNITS
$\overline{RESET}$ Output-Voltage Low	$V_{OL}$	$V_{CC} = 3.3V$ , $I_{SINK} = 10mA$ , $\overline{RESET}$ asserted			0.30	V
		$V_{CC} = 2.5V$ , $I_{SINK} = 6mA$ , $\overline{RESET}$ asserted			0.30	
		$V_{CC} = 1.2V$ , $I_{SINK} = 50\mu A$ , $\overline{RESET}$ asserted			0.30	
$\overline{RESET}$ Output-Voltage High	$V_{OH}$	$V_{CC} \geq 2.0V$ , $I_{SOURCE} = 6\mu A$ , $\overline{RESET}$ deasserted	$0.8 \times V_{CC}$			V
$\overline{MR}$ Input-Voltage Low	$V_{IL}$				$0.3 \times V_{CC}$	V
$\overline{MR}$ Input-Voltage High	$V_{IH}$		$0.7 \times V_{CC}$			V
$\overline{MR}$ Minimum Pulse Width			1			$\mu s$
$\overline{MR}$ Glitch Rejection				100		ns
$\overline{MR}$ to $\overline{RESET}$ Delay				200		ns
$\overline{MR}$ Pullup Resistance			12	20	28	$k\Omega$
<b>OUTPUTS (<math>\overline{UVOUT}_-</math>/<math>\overline{OVOUT}_-</math>)</b>						
$\overline{UVOUT}_-$ , $\overline{OVOUT}_-$ Output-Voltage Low	$V_{OL}$	$V_{CC} = 3.3V$ , $I_{SINK} = 2mA$			0.30	V
		$V_{CC} = 2.5V$ , $I_{SINK} = 1.2mA$			0.30	
$\overline{OVOUT}_-$ , $\overline{OVOUT}_-$ Output-Voltage High	$V_{OH}$	$V_{CC} \geq 2.0V$ , $I_{SOURCE} = 6\mu A$	$0.8 \times V_{CC}$			V
$\overline{UVIN}_-$ / $\overline{OVIN}_-$ to $\overline{UVOUT}_-$ / $\overline{OVOUT}_-$ Propagation Delay	$t_D$	( $V_{TH} - 100mV$ ) to ( $V_{TH} + 100mV$ )		20		$\mu s$
<b>DIGITAL LOGIC</b>						
TOL Input-Voltage Low	$V_{IL}$				$0.3 \times V_{CC}$	V
TOL Input-Voltage High	$V_{IH}$		$0.7 \times V_{CC}$			V
TOL Input Current		$TOL = V_{CC}$			100	nA
$\overline{MARGIN}$ Input-Voltage Low	$V_{IL}$				$0.3 \times V_{CC}$	V
$\overline{MARGIN}$ Input-Voltage High	$V_{IH}$		$0.7 \times V_{CC}$			V
$\overline{MARGIN}$ Pullup Resistance		Pulled up to $V_{CC}$	12	20	28	$k\Omega$
$\overline{MARGIN}$ Delay Time	$t_{MD}$	Rising or falling (Note 5)		50		$\mu s$

**Note 1:** Devices are tested at  $T_A = +25^{\circ}C$  and guaranteed by design for  $T_A = T_{MIN}$  to  $T_{MAX}$ .

**Note 2:** The outputs are guaranteed to be in the correct logic state down to  $V_{CC} = 1V$ .

**Note 3:** Measured with  $\overline{MR}$  and  $\overline{MARGIN}$  unconnected.

**Note 4:** The minimum and maximum specifications for this parameter are guaranteed by using the worse case of the SRT current and SRT threshold specifications. Do not set the reset timeout period to more than 1.12s.

**Note 5:** Amount of time required for logic to lock/unlock outputs from margin testing

# Low-Voltage, High-Accuracy, Quad Window Voltage Detectors in Thin QFN

## Typical Operating Characteristics

( $V_{CC} = 3.3V$ ,  $T_A = +25^\circ C$ , unless otherwise noted.)

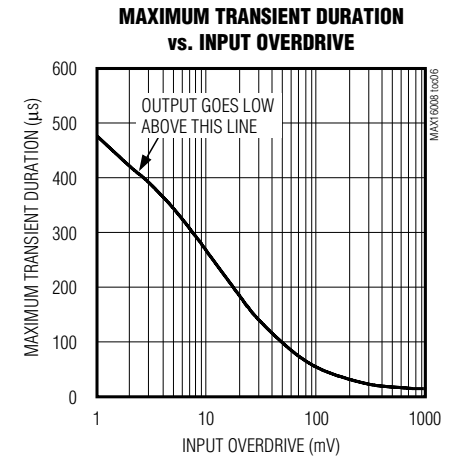
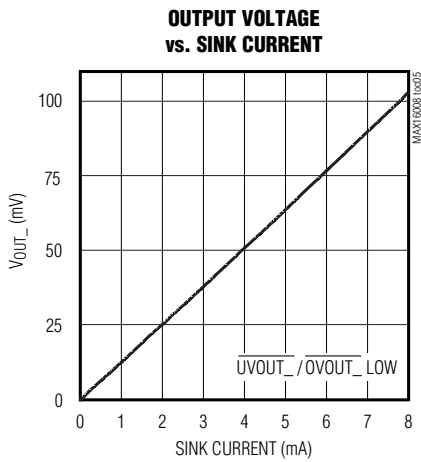
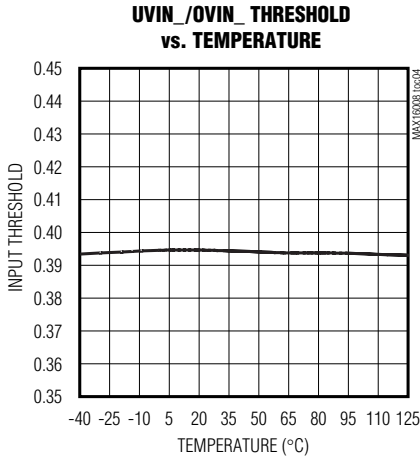
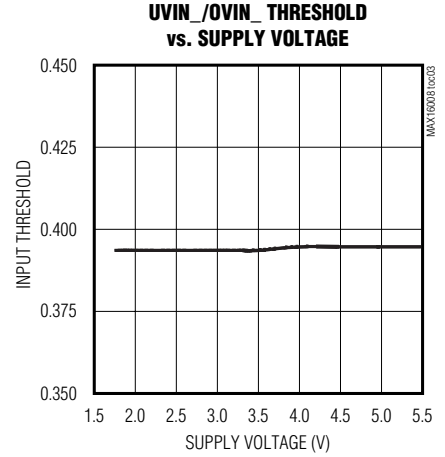
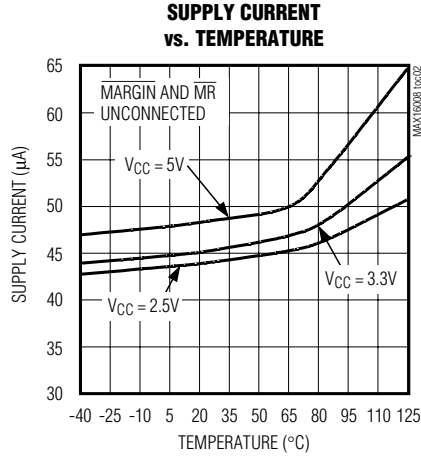
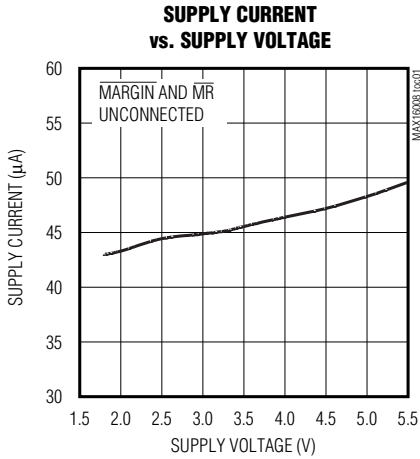

# Low-Voltage, High-Accuracy, Quad Window Voltage Detectors in Thin QFN

## Typical Operating Characteristics (continued)

( $V_{CC} = 3.3V$ ,  $T_A = +25^\circ C$ , unless otherwise noted.)

MAX16008/MAX16009

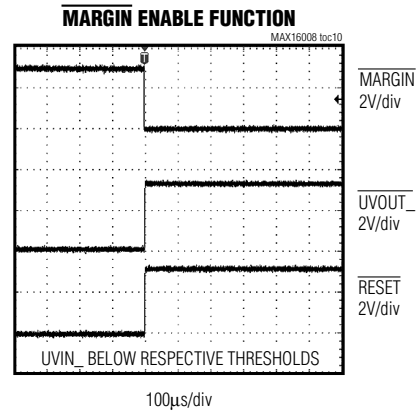
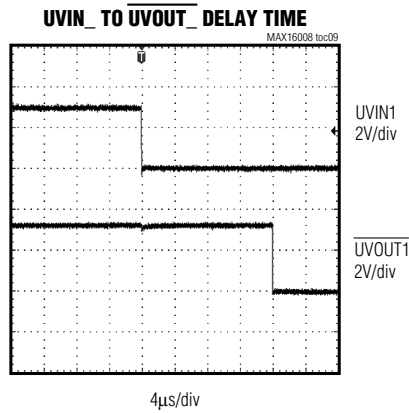
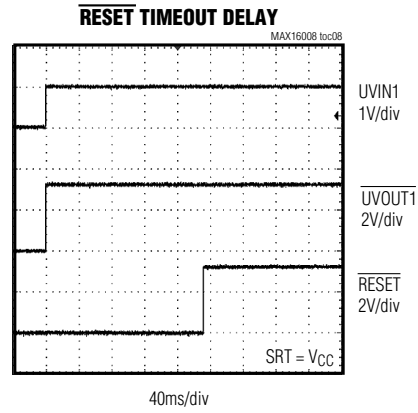
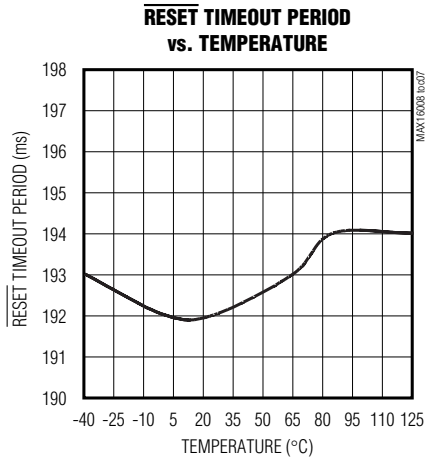

# Low-Voltage, High-Accuracy, Quad Window Voltage Detectors in Thin QFN

## Pin Description

PIN		NAME	FUNCTION
MAX16008	MAX16009		
1	1	UVIN3	Undervoltage Threshold Input 3. When the voltage on UVIN3 falls below its threshold, $\overline{UVOUT3}$ asserts low.
2	2	OVIN3	Overvoltage Threshold Input 3. When the voltage on OVIN3 rises above its threshold, $\overline{OVOUT3}$ asserts low.
3	3	UVIN4	Undervoltage Threshold Input 4. When the voltage on UVIN4 falls below its threshold, $\overline{UVOUT4}$ asserts low.
4	4	OVIN4	Overvoltage Threshold Input 4. When the voltage on OVIN4 rises above its threshold, $\overline{OVOUT4}$ asserts low.
5	6	GND	Ground
6, 20	7, 24	VCC	Unmonitored Power to the Device
7	8	$\overline{UVOUT3}$	Active-Low Undervoltage Output 3. When the voltage at UVIN3 falls below its threshold, $\overline{UVOUT3}$ asserts low and stays asserted until the voltage at UVIN3 exceeds its threshold. The open-drain output has a 30 $\mu$ A internal pullup to VCC.
8	9	$\overline{OVOUT3}$	Active-Low Overvoltage Output 3. When the voltage at OVIN3 rises above its threshold, $\overline{OVOUT3}$ asserts low and stays asserted until the voltage at OVIN3 falls below its threshold. The open-drain output has a 30 $\mu$ A internal pullup to VCC.
9	10	$\overline{UVOUT4}$	Active-Low Undervoltage Output 4. When the voltage at UVIN4 falls below its threshold, $\overline{UVOUT4}$ asserts low and stays asserted until the voltage at UVIN4 exceeds its threshold. The open-drain output has a 30 $\mu$ A internal pullup to VCC.
10	11	$\overline{OVOUT4}$	Active-Low Overvoltage Output 4. When the voltage at OVIN4 rises above its threshold, $\overline{OVOUT4}$ asserts low and stays asserted until the voltage at OVIN4 falls below its threshold. The open-drain output has a 30 $\mu$ A internal pullup to VCC.
11	14	$\overline{MARGIN}$	Active-Low Margin Enable Input. Pull $\overline{MARGIN}$ low to deassert all outputs (go into high state) regardless of the voltage at any monitored input.
12	15	$\overline{OVOUT2}$	Active-Low Overvoltage Output 2. When the voltage at OVIN2 rises above its threshold, $\overline{OVOUT2}$ asserts low and stays asserted until the voltage at OVIN2 falls below its threshold. The open-drain output has a 30 $\mu$ A internal pullup to VCC.

# Low-Voltage, High-Accuracy, Quad Window Voltage Detectors in Thin QFN

## Pin Description (continued)

**MAX16008/MAX16009**

PIN		NAME	FUNCTION
MAX16008	MAX16009		
13	16	$\overline{UVOUT2}$	Active-Low Undervoltage Output 2. When the voltage at UVIN2 falls below its threshold, $\overline{UVOUT2}$ asserts low and stays asserted until the voltage at UVIN2 exceeds its threshold. The open-drain output has a 30 $\mu$ A internal pullup to V <sub>CC</sub> .
14	17	$\overline{OVOUT1}$	Active-Low Overvoltage Output 1. When the voltage at OVIN1 rises above its threshold, $\overline{OVOUT1}$ asserts low and stays asserted until the voltage at OVIN1 falls below its threshold. The open-drain output has a 30 $\mu$ A internal pullup to V <sub>CC</sub> .
15	18	$\overline{UVOUT1}$	Active-Low Undervoltage Output 1. When the voltage at UVIN1 falls below its threshold, $\overline{UVOUT1}$ asserts low and stays asserted until the voltage at UVIN1 exceeds its threshold. The open-drain output has a 30 $\mu$ A internal pullup to V <sub>CC</sub> .
16	20	UVIN1	Undervoltage Threshold Input 1. When the voltage on UVIN1 falls below its threshold, $\overline{UVOUT1}$ asserts low.
17	21	OVIN1	Overvoltage Threshold Input 1. When the voltage on OVIN1 rises above its threshold, $\overline{OVOUT1}$ asserts low.
18	22	UVIN2	Undervoltage Threshold Input 2. When the voltages on UVIN2 falls below its threshold, $\overline{UVOUT2}$ asserts low.
19	23	OVIN2	Overvoltage Threshold Input 2. When the voltage on OVIN2 rises above its threshold, $\overline{OVOUT2}$ asserts low.
—	5	N.C.	Not Internally Connected
—	12	$\overline{MR}$	Active-Low Manual Reset Input. Pull $\overline{MR}$ low to assert $\overline{RESET}$ low. $\overline{RESET}$ remains low for the reset timeout period after $\overline{MR}$ is deasserted. $\overline{MR}$ is pulled up to V <sub>CC</sub> through a 20k $\Omega$ resistor.
—	13	SRT	Set Reset Timeout Input. Connect a capacitor from SRT to GND to set the reset timeout period. The reset timeout period can be calculated as follows: Reset Timeout (s) = 2.06 × 10 <sup>6</sup> ( $\Omega$ ) × C <sub>SRT</sub> (F). Do not set the reset timeout period to more than 1.12s. For the internal timeout period of 140ms (min), connect SRT to V <sub>CC</sub> .
—	19	$\overline{RESET}$	Active-Low Reset Output. $\overline{RESET}$ asserts low when the voltage on any of the UVIN_ inputs falls below their respective thresholds, the voltage on any of the OVIN_ inputs goes above its respective threshold, or $\overline{MR}$ is asserted. $\overline{RESET}$ remains asserted for at least the minimum reset timeout after all monitored UVIN_ inputs exceed their respective thresholds, all OVIN_ inputs fall below their respective thresholds, and $\overline{MR}$ is deasserted. This open-drain output has a 30 $\mu$ A internal pullup.
EP	EP	EP	Exposed Pad. EP is internally connected to GND. Connect EP to the ground plane to provide a low thermal resistance path from the IC junction to the PC board. Do not use as the only electrical connection to GND.

# Low-Voltage, High-Accuracy, Quad Window Voltage Detectors in Thin QFN

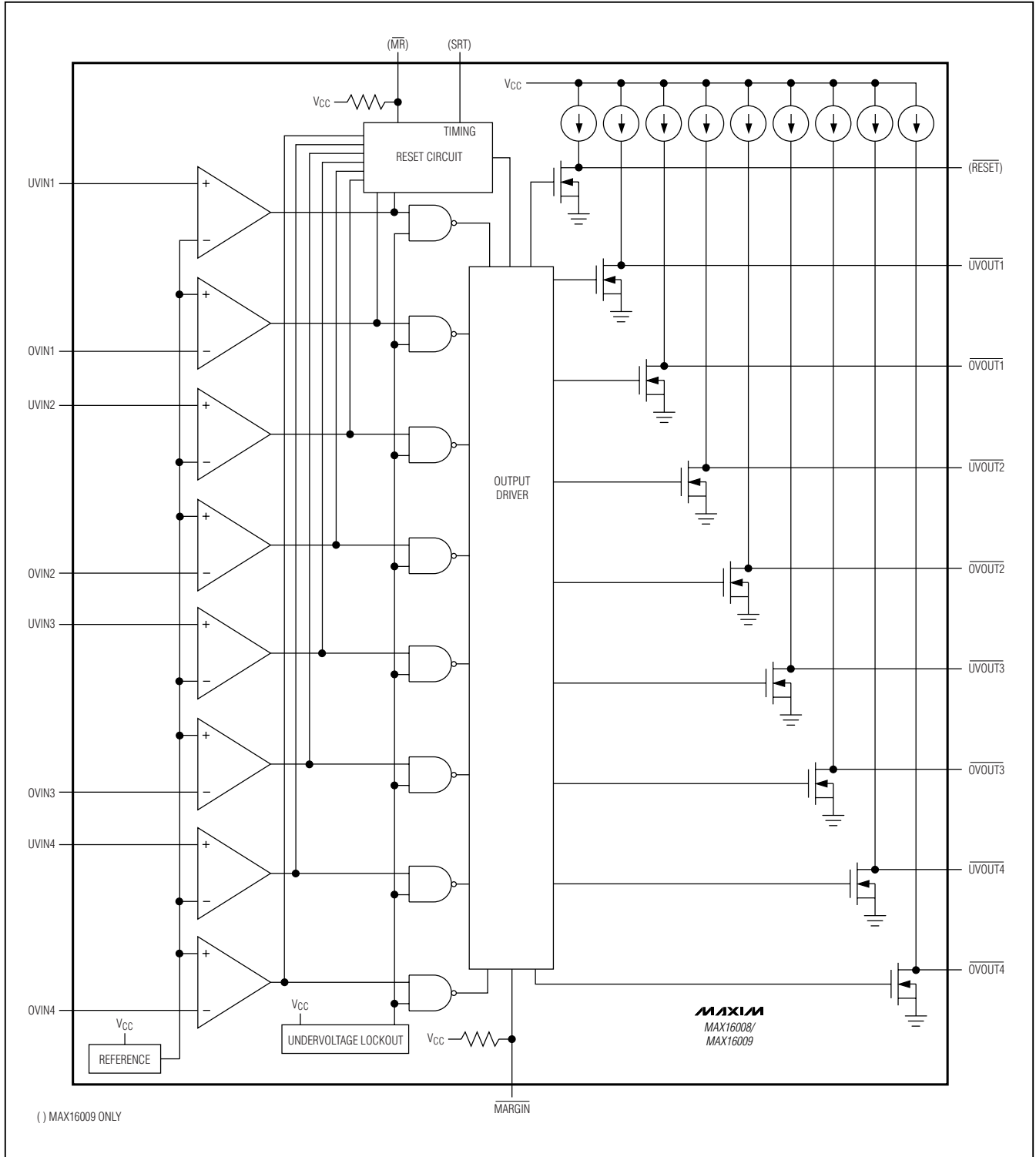

( ) MAX16009 ONLY

Figure 1. Functional Diagram



# Low-Voltage, High-Accuracy, Quad Window Voltage Detectors in Thin QFN

MAX16008/MAX16009

## Detailed Description

The MAX16008/MAX16009 are adjustable quad window voltage detectors in a small thin QFN package. These devices are designed to provide a higher level of system reliability by monitoring multiple supply voltages and providing a fault signal when any of the voltages exceeds its overvoltage threshold or falls below its undervoltage threshold.

These devices offer user-adjustable thresholds that allow voltages to be monitored down to 0.4V. The devices allow the upper and lower trip thresholds of each window detector to be set externally with the use of three external resistors.

Each monitored threshold has an independent open-drain output for signaling a fault condition. The outputs can be wire OR'ed together to provide a single fault output. The open-drain outputs are internally pulled up with a 30μA current, but can be externally driven to other voltage levels for interfacing to other logic levels.

Both devices feature a margin input to disable the outputs during margin testing or any other time after power-up operations. The MAX16009 offers a reset output that deasserts after a reset timeout period after all voltages are within their threshold specification. The reset timeout is internally set to 140ms (min), but can be externally adjusted to other reset timeouts using an external capacitor. In addition, the MAX16009 offers a manual reset input.

## Applications Information

### Voltage Monitoring

The MAX16008/MAX16009 feature undervoltage and overvoltage comparators for window detection (see Figure 2).  $\overline{UVOUT\_}$ / $\overline{OVOUT\_}$  deassert high when the monitored voltage is within the "selected window." When the monitored voltage falls below the lower limit of the window ( $V_{TRIPLOW}$ ),  $\overline{UVOUT\_}$  asserts low; or if the monitored voltage exceeds the upper limit ( $V_{TRIPHIGH}$ ),  $\overline{OVOUT\_}$  asserts low. The application in Figure 2 shows the MAX16008/MAX16009 enabling the DC-DC converter when the monitored voltage is in the selected window.

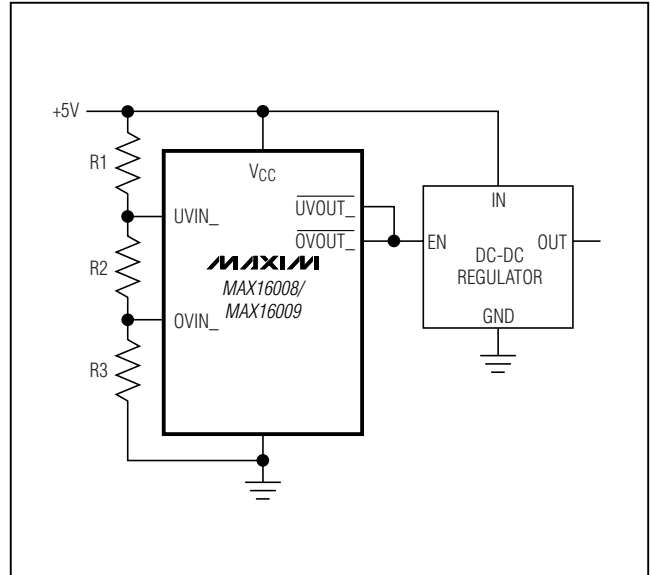

Figure 2. MAX16008/MAX16009 Monitor Circuit

The resistor values R1, R2, and R3 can be calculated as shown:

$$V_{TRIPLOW} = V_{TH} \left( \frac{R_{TOTAL}}{R2 + R3} \right)$$

$$V_{TRIPHIGH} = V_{TH} \left( \frac{R_{TOTAL}}{R3} \right)$$

where  $R_{TOTAL} = R1 + R2 + R3$ .

Use the following steps to determine the values for R1, R2, and R3:

- 1) Choose a value for  $R_{TOTAL}$ , the sum of R1, R2, and R3. Because the MAX16008/MAX16009 have very low input bias current (2nA typ),  $R_{TOTAL}$  can be up to 2MΩ. Large-value resistors help minimize power consumption. Lower-value resistors can be used to maintain overall accuracy.

# Low-Voltage, High-Accuracy, Quad Window Voltage Detectors in Thin QFN

Use the following formulas to calculate the error:

$$E_{UV}(\%) = \frac{I_B \left( R_1 + \frac{R_1 R_3}{R_2 + R_3} \right)}{V_{TRIPLOW}} \times 100$$

$$E_{OV}(\%) = \frac{I_B (R_2 + (2 \times R_1))}{V_{TRIPHIGH}} \times 100$$

where  $E_{UV}$  and  $E_{OV}$  are the undervoltage and overvoltage error (in %), respectively.

- Calculate  $R_3$  based on  $R_{TOTAL}$  and the desired upper trip point:

$$R_3 = \frac{V_{TH} \times R_{TOTAL}}{V_{TRIPHIGH}}$$

- Calculate  $R_2$  based on  $R_{TOTAL}$ ,  $R_3$ , and the desired lower trip point:

$$R_2 = \frac{V_{TH} \times R_{TOTAL}}{V_{TRIPLOW}} - R_3$$

- Calculate  $R_1$  based on  $R_{TOTAL}$ ,  $R_3$ , and  $R_2$ :

$$R_1 = R_{TOTAL} - R_2 - R_3$$

### Overvoltage Shutdown

The MAX16008/MAX16009 are ideal for overvoltage-shutdown applications. Figure 3 shows a typical circuit for this application using a pass p-channel MOSFET.

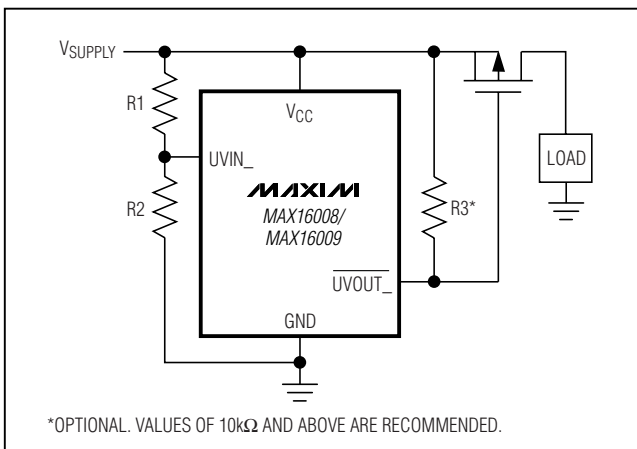

Figure 3. Overvoltage Shutdown Circuit (with External Pass MOSFET)

The MAX16008/MAX16009 are powered directly from the system voltage supply. Select  $R_1$  and  $R_2$  to set the trip voltage. When the supply voltage remains below the selected threshold, a low logic level on  $\overline{UVOUT}_-$  turns on the p-channel MOSFET. In the case of an overvoltage event,  $\overline{UVOUT}_-$  goes high turning off the MOSFET, and shuts down the power to the load.

Figure 4 shows a similar application using a fuse and a silicon-controlled rectifier (SCR). An overvoltage event turns on the SCR and shorts the supply to ground. The surge of current through the short circuit blows the fuse and terminates the current to the load. Select  $R_3$  so that the gate of the SCR is properly biased when  $\overline{UVOUT}_-$  goes high.

### Unused Inputs

Any unused  $\overline{UVIN}_-$  inputs must be connected to  $V_{CC}$ , and any unused  $\overline{OVIN}_-$  inputs must be connected to GND.

### $\overline{UVOUT}_-$ / $\overline{OVOUT}_-$ Outputs

$\overline{UVOUT}_-$  and  $\overline{OVOUT}_-$  outputs assert low when  $\overline{UVIN}_-$  and  $\overline{OVIN}_-$ , respectively, drop below or exceed their specified thresholds. The undervoltage/overvoltage outputs are open-drain with a (30 $\mu$ A) internal pullup to  $V_{CC}$ . For many applications, no external pullup resistor is required to interface with other logic devices. An external pullup resistor to any voltage up to 5.5V overdrives the internal pullup if interfacing to different logic supply voltages. Internal circuitry prevents reverse current flow from the external pullup voltage to  $V_{CC}$  (Figure 5). When choosing the external pullup resistor, the resistance value should be large enough to ensure that the output can sink the necessary current during a logic-low condition and small enough to be able to overdrive the internal pullup current and meet output high specifications

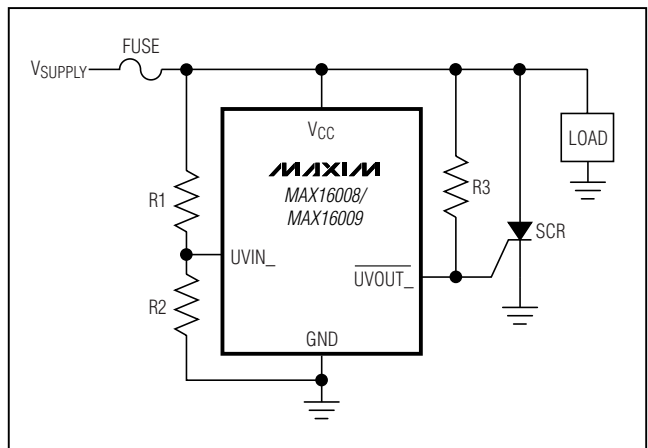

Figure 4. Overvoltage Shutdown Circuit (with SCR Fuse)

# Low-Voltage, High-Accuracy, Quad Window Voltage Detectors in Thin QFN

(VOH). Resistor values of 50kΩ to 200kΩ can generally be used.

## RESET Output (MAX16009 Only)

RESET asserts low when the voltage on any of the UVIN\_ inputs falls below its respective threshold, the voltage on any of the OVIN\_ inputs goes above its respective threshold, or MR is asserted. RESET remains asserted for the reset timeout period after all monitored UVIN\_ inputs exceed their respective thresholds, all OVIN\_ inputs fall below their respective thresholds, and MR is deasserted (see Figure 6). This open-drain output has a 30μA internal pullup.

## Reset Timeout Capacitor

The reset timeout period can be adjusted to accommodate a variety of microprocessor (μP) applications from 50μs to 1.12s. Adjust the reset timeout period (tRP) by connecting a capacitor (CSRT) between SRT and GND. Calculate the reset timeout capacitor as follows:

$$C_{SRT} (F) = \frac{t_{RP} (s)}{\left( \frac{V_{TH\_SRT}}{I_{SRT}} \right)}$$

Do not use capacitor (CSRT) values higher than 390nF.

Connect SRT to VCC for a factory-programmed reset timeout of 140ms (min).

## Manual Reset Input (MR) (MAX16009 Only)

Many μP-based products require manual reset capability, allowing the operator, a test technician, or external logic circuitry to initiate a reset. A logic-low on MR asserts RESET low. RESET remains asserted while MR is low, and during the reset timeout period (140ms min) after MR returns high. The MR input has an internal 20kΩ pullup resistor to VCC, so it can be left open if it is not used. MR can be driven with TTL or CMOS-logic levels, or with open-drain/collector outputs. Connect a normally open momentary switch from MR to GND to create a manual reset function; external debounce circuitry is not required. If MR is driven from long cables or if the device is used in a noisy environment, connecting a 0.1μF capacitor from MR to GND provides additional noise immunity.

## Margin Output Disable (MARGIN)

MARGIN allows system-level testing while power supplies are adjusted from their nominal voltages. Drive MARGIN low to deassert all outputs (UVOUT\_

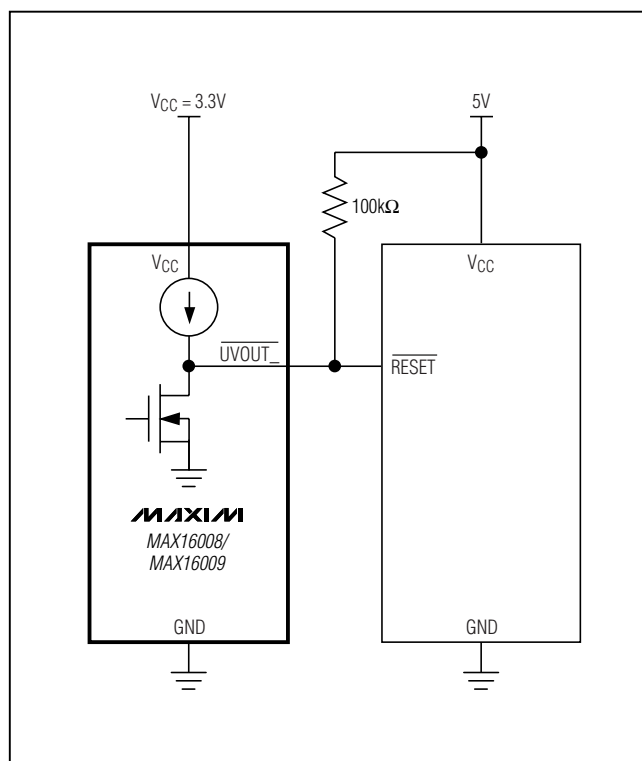

Figure 5. Interfacing to a Different Logic Supply Voltage

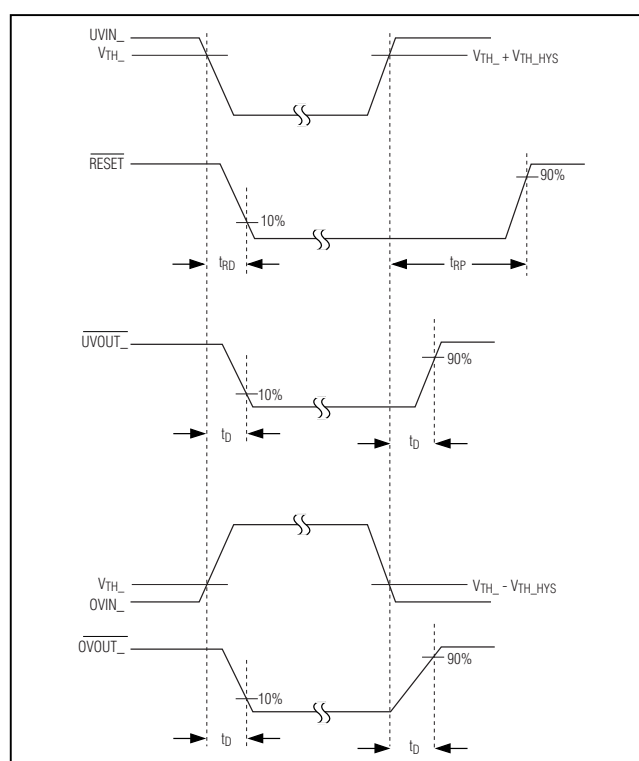

Figure 6. Output Timing Diagram

# Low-Voltage, High-Accuracy, Quad Window Voltage Detectors in Thin QFN

$\overline{\text{OVOUT}}_i$ , and  $\overline{\text{RESET}}$ ) regardless of the voltage at any monitored input. The state of each output does not change while  $\overline{\text{MARGIN}} = \text{GND}$ . While  $\overline{\text{MARGIN}}$  is low, the IC continues to monitor all voltages. When  $\overline{\text{MARGIN}}$  is deasserted, the outputs go to their monitored states after a short propagation delay. The  $\overline{\text{MARGIN}}$  input is internally pulled up to  $V_{\text{CC}}$ . Leave unconnected or connect to  $V_{\text{CC}}$  if unused.

### Power-Supply Bypassing

The MAX16008/MAX16009 operate from a 2.0V to 5.5V supply. An undervoltage lockout ensures that the outputs are in the correct states when the UVLO is exceeded. In noisy applications, bypass  $V_{\text{CC}}$  to ground with a 0.1 $\mu\text{F}$  capacitor as close to the device as possible. In addition, the additional capacitor improves transient immunity. For fast-rising  $V_{\text{CC}}$  transients, additional capacitance may be required.

### Selector Guide

PART	NUMBER OF MONITORED LEVELS	UNDERVOLTAGE/OVERVOLTAGE THRESHOLDS	$\overline{\text{RESET}}$	ADJUSTABLE RESET TIMEOUT	$\overline{\text{MR}}$
MAX16008	4	Adjustable	—	—	—
MAX16009	4	Adjustable	✓	✓	✓

### Pin Configurations

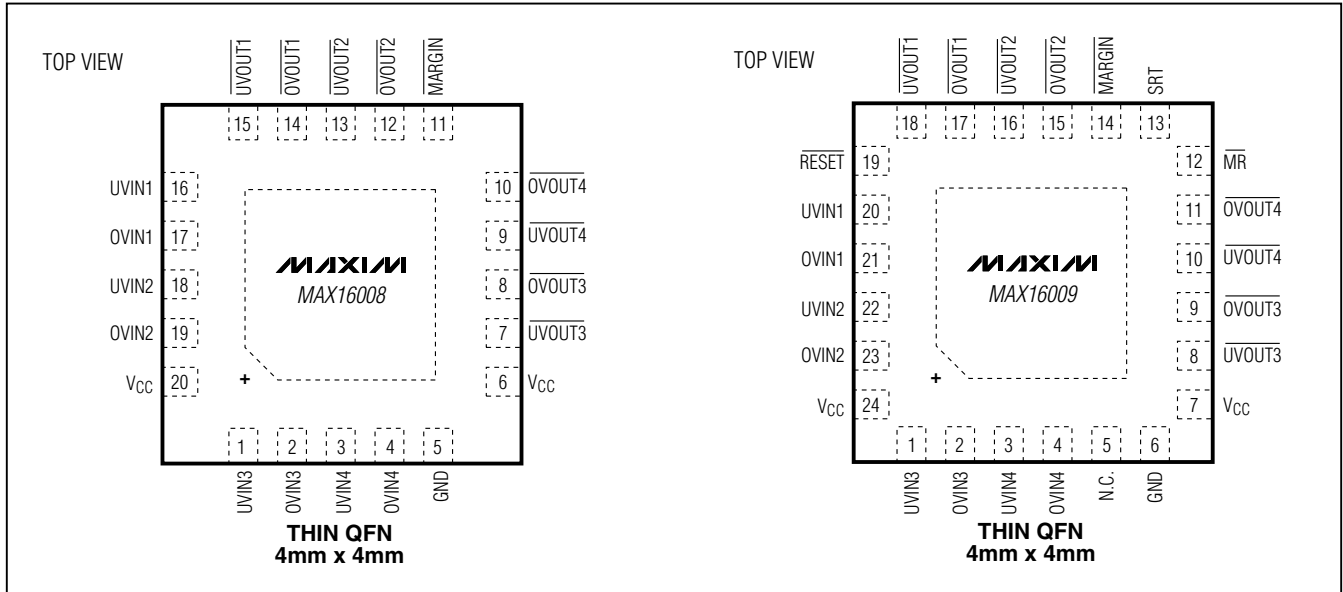

# Low-Voltage, High-Accuracy, Quad Window Voltage Detectors in Thin QFN

## Package Information

(The package drawing(s) in this data sheet may not reflect the most current specifications. For the latest package outline information go to [www.maxim-ic.com/packages](http://www.maxim-ic.com/packages).)

MAX16008/MAX16009

24L QFN THIN.EPS

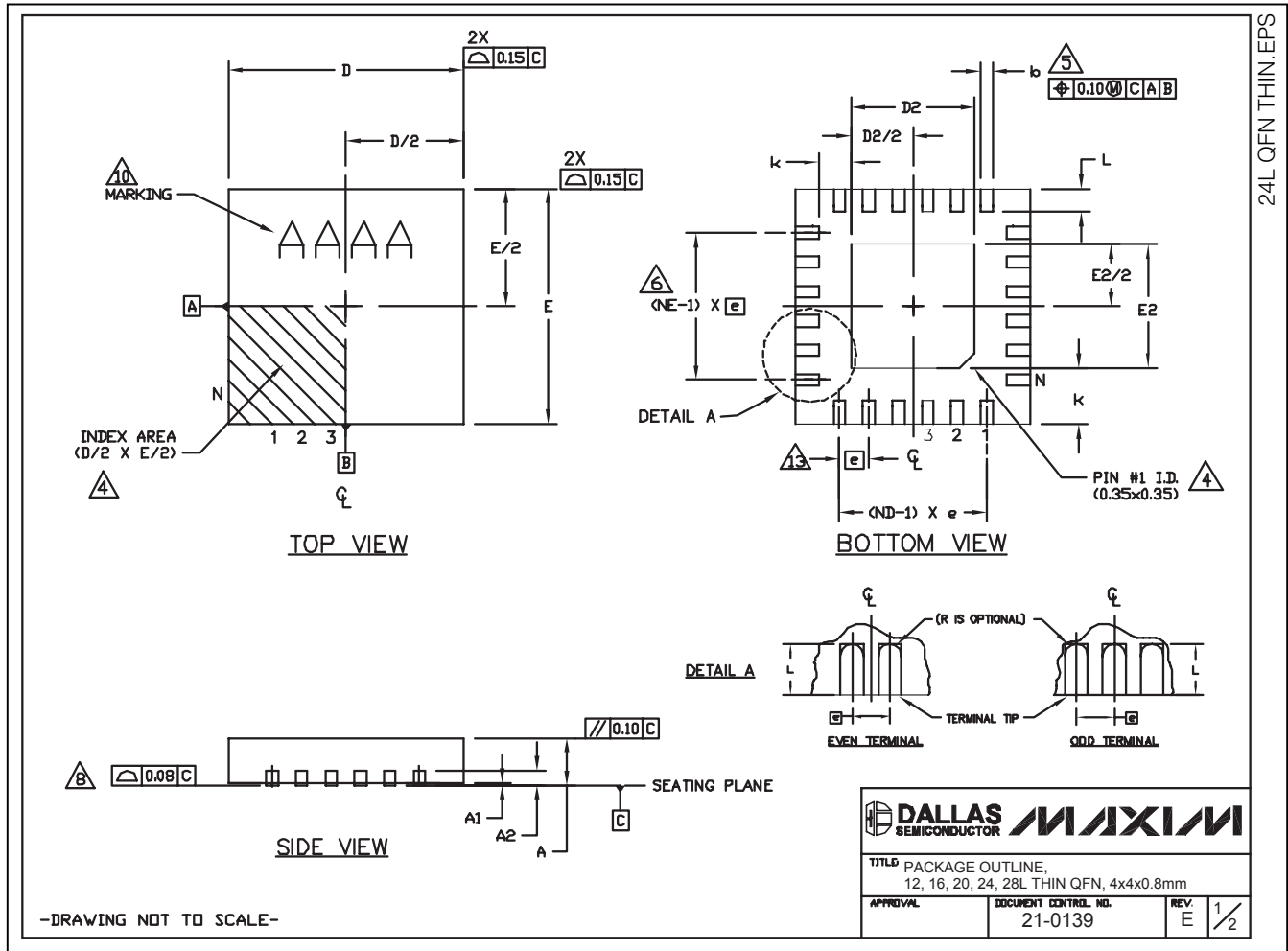

# Low-Voltage, High-Accuracy, Quad Window Voltage Detectors in Thin QFN

## Package Information (continued)

(The package drawing(s) in this data sheet may not reflect the most current specifications. For the latest package outline information go to [www.maxim-ic.com/packages](http://www.maxim-ic.com/packages).)

COMMON DIMENSIONS															
PKG REF.	12L 4x4			16L 4x4			20L 4x4			24L 4x4			28L 4x4		
	MIN.	NOM.	MAX.	MIN.	NOM.	MAX.	MIN.	NOM.	MAX.	MIN.	NOM.	MAX.	MIN.	NOM.	MAX.
A	0.70	0.75	0.80	0.70	0.75	0.80	0.70	0.75	0.80	0.70	0.75	0.80	0.70	0.75	0.80
A1	0.0	0.02	0.05	0.0	0.02	0.05	0.0	0.02	0.05	0.0	0.02	0.05	0.0	0.02	0.05
A2	0.20 REF			0.20 REF			0.20 REF			0.20 REF			0.20 REF		
b	0.25	0.30	0.35	0.25	0.30	0.35	0.20	0.25	0.30	0.18	0.23	0.30	0.15	0.20	0.25
D	3.90	4.00	4.10	3.90	4.00	4.10	3.90	4.00	4.10	3.90	4.00	4.10	3.90	4.00	4.10
E	3.90	4.00	4.10	3.90	4.00	4.10	3.90	4.00	4.10	3.90	4.00	4.10	3.90	4.00	4.10
e	0.80 BSC.			0.65 BSC.			0.50 BSC.			0.50 BSC.			0.40 BSC.		
k	0.25	-	-	0.25	-	-	0.25	-	-	0.25	-	-	0.25	-	-
L	0.45	0.55	0.65	0.45	0.55	0.65	0.45	0.55	0.65	0.30	0.40	0.50	0.30	0.40	0.50
N	12			16			20			24			28		
ND	3			4			5			6			7		
NE	3			4			5			6			7		
JeDEC Ver.	VGG3			VGGC			WGGD-1			WGGD-2			WGGE		

EXPOSED PAD VARIATIONS							
PKG CODES	D2			E2			DOWN BONDS ALLOWED
	MIN.	NOM.	MAX.	MIN.	NOM.	MAX.	
T1244-3	1.95	2.10	2.25	1.95	2.10	2.25	YES
T1244-4	1.95	2.10	2.25	1.95	2.10	2.25	NO
T1644-3	1.95	2.10	2.25	1.95	2.10	2.25	YES
T1644-4	1.95	2.10	2.25	1.95	2.10	2.25	NO
T2044-2	1.95	2.10	2.25	1.95	2.10	2.25	YES
T2044-3	1.95	2.10	2.25	1.95	2.10	2.25	NO
T2444-2	1.95	2.10	2.25	1.95	2.10	2.25	YES
T2444-3	2.45	2.60	2.63	2.45	2.60	2.63	YES
T2444-4	2.45	2.60	2.63	2.45	2.60	2.63	NO
T2844-1	2.50	2.60	2.70	2.50	2.60	2.70	NO

**NOTES:**

- DIMENSIONING & TOLERANCING CONFORM TO ASME Y14.5M-1994.
- ALL DIMENSIONS ARE IN MILLIMETERS. ANGLES ARE IN DEGREES.
- N IS THE TOTAL NUMBER OF TERMINALS.
- THE TERMINAL #1 IDENTIFIER AND TERMINAL NUMBERING CONVENTION SHALL CONFORM TO JEDEC 95-1 SPP-012. DETAILS OF TERMINAL #1 IDENTIFIER ARE OPTIONAL, BUT MUST BE LOCATED WITHIN THE ZONE INDICATED. THE TERMINAL #1 IDENTIFIER MAY BE EITHER A MOLD OR MARKED FEATURE.
- DIMENSION b APPLIES TO METALLIZED TERMINAL AND IS MEASURED BETWEEN 0.25 mm AND 0.30 mm FROM TERMINAL TIP.
- ND AND NE REFER TO THE NUMBER OF TERMINALS ON EACH D AND E SIDE RESPECTIVELY.
- DEPOPULATION IS POSSIBLE IN A SYMMETRICAL FASHION.
- COPLANARITY APPLIES TO THE EXPOSED HEAT SINK SLUG AS WELL AS THE TERMINALS.
- DRAWING CONFORMS TO JEDEC MO220, EXCEPT FOR T2444-3, T2444-4 AND T2844-1.
- MARKING IS FOR PACKAGE ORIENTATION REFERENCE ONLY.
- COPLANARITY SHALL NOT EXCEED 0.08mm
- WARPAGE SHALL NOT EXCEED 0.10mm
- LEAD CENTERLINES TO BE AT TRUE POSITION AS DEFINED BY BASIC DIMENSION "e", ±0.05.
- NUMBER OF LEADS SHOWN ARE FOR REFERENCE ONLY

-DRAWING NOT TO SCALE-

	
TITLE PACKAGE OUTLINE, 12, 16, 20, 24, 28L THIN QFN, 4x4x0.8mm	
APPROVAL	DOCUMENT CONTROL NO. 21-0139
REV. E	2/2

Maxim cannot assume responsibility for use of any circuitry other than circuitry entirely embodied in a Maxim product. No circuit patent licenses are implied. Maxim reserves the right to change the circuitry and specifications without notice at any time.